



## Description

Metal Oxide Varistor (MOV) as one nonlinear resistance element is mainly made of zinc oxide (ZnO), which has very high surge capacity and big nonlinear coefficient. Below the threshold voltage, its resistance is very high, nearly no current flows through, but above the threshold voltage, the resistance reduces sharply, huge current can be discharged. Due to this characteristic, varistor as a protection component in electronic and electrical equipment can absorb abnormal over-voltage and lightning surge.

SETsafe | SETfuse varistor is with High Surge Current Density, Low Clamping Voltage, and Good Surge Capacity. It can also be customized as required.

## Features

- Epoxy Resin Coating
- Silicone Resin Coating
- Low Leakage Current
- Bidirectional and Symmetrical V/I Characteristics
- RoHS & REACH Compliant
- Operating Temperature Range  
Low Temperature: -40 °C  
High Temperature: +125 °C

## Applications

- Power Supplies
- Home Electrical Appliances
- Industrial Devices
- Surge Protectors
- Telecom Devices

## Product Structure

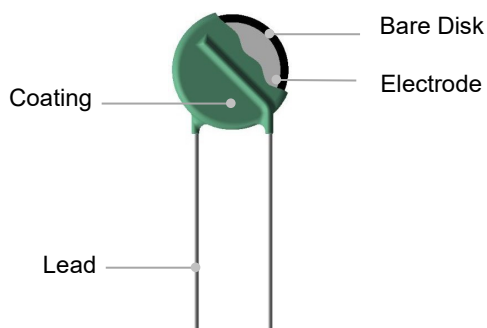

## Lead Types

Lead Types		Codes
	Straight Lead	A
	Inward Crimp Lead	B
	Outward Crimp Lead	C
	Inline Crimp Lead	D
	Little Straight Lead	I

## Agency Approvals

Agency	Standards	No.
	UL 1449 4 <sup>th</sup> Edition	E322662
	CSA C22.2 NO.269.5-17	E322662
	EN 61051-1:2008 IEC 61051-1:2007 IEC 61051-2:1991+A1 IEC 61051-2-2:1991 Annex G 8.1 of IEC 62368-1:2018	J 50239739
	GB/T 10193-1997 GB/T 10194-1997 GB 4943.1-2011 GB 8898-2011	CQC16001152393

### Marking

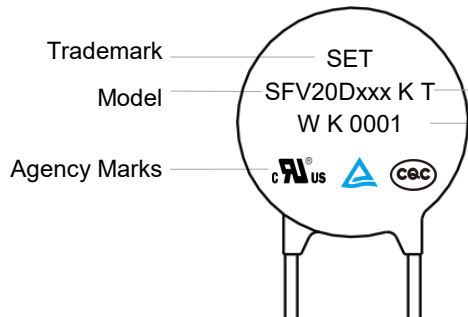

T: High Temp. Series	
Internal code	
Year Code	2000—A ..... 2022—W
Surge Level	S: Normal Type K: Standard Type H: High Energy Type Q: Advanced Type
Serial No.	(E.G.: 0001)

### Temp. Derating Curve

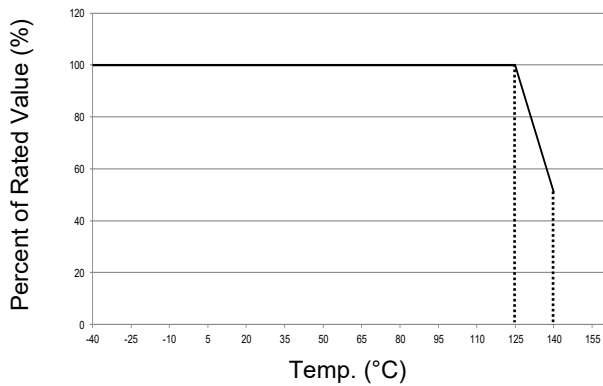

Note:

For high temp. series, when ambient temp. exceeds 125 °C, the peak surge current and energy rating should be reduced as shown in the left curve.

For High Temp. Series Products

### General Technical Data

Item	Value	Unit
Operating Temperature	-40 to +125	°C
Storage Temperature	-40 to +150	°C
Voltage Proof	≥1000	V <sub>ac</sub>
Insulation Resistance	≥100	MΩ

## Part Numbering System

SFV 20 D 471 - K T K A BUL - 001

MOV

MOV

### Other Options

#### \*Packaging & Lead Length

BUL: Bulk + Standard Lead Length (Normal L7)  
 C35: Bulk + Cut to 3.5 mm  
 (Range:2.5 mm to 6 mm)  
 L30: Bulk + Special Lead Length 30 mm  
 (28 mm to 32 mm)  
 (0/1)AB: Taping + Box (Hole Pitch 12.7 mm)  
 (0/1)EB: Taping + Box (Hole Pitch 15.0 mm)  
 (0/1)AR: Taping + Reel (Hole Pitch 12.7 mm)  
 (0/1)ER: Taping + Reel (Hole Pitch 15.0 mm)  
 Note:0/1 Means Product Position  
 0: In Middle of Two Holes; 1: Across the Hole

#### Lead Types

A: Straight Lead  
 B: Inward Crimp Lead  
 C: Outward Crimp Lead  
 D: Inline Crimp Lead  
 I : Little Straight Lead

#### Surge Level

S: Normal Type  
 K: Standard Type  
 Q: Advanced Type  
 H: High Energy Type

#### Operating Temp.

T: Silicone Coating 125 °C

#### Voltage Tolerance

K: ±10%  
 J: ±5%  
 S: Special Tolerance

#### Nominal Varistor Voltage

220:  $22 \times 10^0 = 22 \text{ V}$   
 471:  $47 \times 10^1 = 470 \text{ V}$   
 122:  $12 \times 10^2 = 1200 \text{ V}$

#### Disk Shape

D: Round

#### Bare Disk Dimension

20: 20 mm

#### Product Category

SETfuse Varistor

\*For more details refer to packaging information.

## Glossary

Item	Description
$V_N$	<b>Nominal Varistor Voltage</b> Voltage, at specified D.C. current used as a reference point in the component characteristics.
$I_L$	<b>Leakage Current</b> Measuring at 75% of varistor voltage.
UCT	<b>Upper Category Temp.</b> Max. ambient temp. for which a varistor has been designed to operate continuously.
LCT	<b>Lower Category Temp.</b> Minimum ambient temp. at which a varistor has been designed to operate continuously.
<b>Max. Peak Current</b>	<b>Max. Peak Current</b> Max. current per pulse, which may be passed by a varistor at an ambient temp. of 25 °C, for a given number of pulses.
$V_C$	<b>Clamping Voltage</b> Peak voltage developed across the varistor terminations under standard atmospheric conditions, when passing an 8/20 $\mu$ s class current pulse.
<b>Voltage Proof</b>	<b>Voltage Proof</b> Max. peak voltage, which may be applied under continuous operating conditions between the varistor terminations and any conducting mounting surface (Applicable only to insulated varistors).
$C_V$	<b>Capacitance</b> Capacitance across the MOV measured at a specified frequency and voltage.
$V_{ac}$	<b>Max. Continuous a.c. Voltage</b> Max. a.c. r.m.s. voltage of a substantially sinusoidal waveform (less than 5% total harmonic distortion) which can be applied to the component under continuous operating conditions at 25 °C.
$V_{dc}$	<b>Max. Continuous d.c. Voltage</b> Max. d.c. voltage (with less than 5% ripple) which can be applied to the component under continuous operating conditions at an ambient temp. of 25 °C.

**Dimensions (mm)**

Model	L (Min.)	H (Max.)	T (Max.)	D (Max.)	d	F	F <sub>1</sub>	A (Max.)
SFV20D220KT	7	25.5	5.3	23	1.00±0.05	10.0±0.6	1.3 - 2.7	27.5
SFV20D270KT	7	25.5	5.6	23	1.00±0.05	10.0±0.6	1.4 - 2.9	27.5
SFV20D330KT	7	25.5	5.9	23	1.00±0.05	10.0±0.6	1.5 - 3.1	27.5
SFV20D390KT	7	25.5	6.2	23	1.00±0.05	10.0±0.6	1.6 - 3.3	27.5
SFV20D470KT	7	25.5	5.4	23	1.00±0.05	10.0±0.6	1.4 - 2.9	27.5
SFV20D560KT	7	25.5	5.6	23	1.00±0.05	10.0±0.6	1.5 - 3.1	27.5
SFV20D680KT	7	25.5	5.9	23	1.00±0.05	10.0±0.6	1.6 - 3.4	27.5
SFV20D820KT	7	25.5	5.2	23	1.00±0.05	10.0±0.6	1.4 - 2.8	27.5
SFV20D101KT	7	25.5	5.4	23	1.00±0.05	10.0±0.6	1.5 - 3.0	27.5
SFV20D121KT	7	25.5	5.6	23	1.00±0.05	10.0±0.6	1.6 - 3.2	27.5
SFV20D151KT	7	25.5	5.9	23	1.00±0.05	10.0±0.6	1.7 - 3.5	27.5
SFV20D181KT	7	25.5	5.3	23	1.00±0.05	10.0±0.6	1.4 - 3.1	27.5
SFV20D201KT	7	25.5	5.5	23	1.00±0.05	10.0±0.6	1.5 - 3.2	27.5
SFV20D221KT	7	25.5	5.6	23	1.00±0.05	10.0±0.6	1.6 - 3.3	27.5
SFV20D241KT	7	25.5	5.7	23	1.00±0.05	10.0±0.6	1.7 - 3.4	27.5
SFV20D271KT	7	25.5	5.9	23	1.00±0.05	10.0±0.6	1.8 - 3.6	27.5
SFV20D301KT	7	25.5	6.1	23	1.00±0.05	10.0±0.6	1.9 - 3.8	27.5
SFV20D331KT	7	25.5	6.2	23	1.00±0.05	10.0±0.6	2.0 - 3.9	27.5
SFV20D361KT	7	25.5	6.4	23	1.00±0.05	10.0±0.6	2.1 - 4.1	27.5
SFV20D391KT	7	25.5	6.6	23	1.00±0.05	10.0±0.6	2.3 - 4.3	27.5
SFV20D431KT	7	25.5	6.8	23	1.00±0.05	10.0±0.6	2.5 - 4.5	27.5
SFV20D471KT	7	25.5	7.1	23	1.00±0.05	10.0±0.6	2.8 - 4.8	27.5
SFV20D511KT	7	25.5	7.3	23	1.00±0.05	10.0±0.6	3.0 - 5.0	27.5
SFV20D561KT	7	25.5	7.6	23	1.00±0.05	10.0±0.6	3.3 - 5.3	27.5
SFV20D621KT	7	25.5	8.0	23	1.00±0.05	10.0±0.6	3.6 - 5.6	27.5
SFV20D681KT	7	25.5	8.4	23	1.00±0.05	10.0±0.6	4.0 - 6.0	27.5
SFV20D751KT	7	25.5	8.8	23	1.00±0.05	10.0±0.6	4.4 - 6.4	27.5
SFV20D821KT	7	25.5	9.2	23	1.00±0.05	10.0±0.6	4.8 - 6.8	27.5
SFV20D911KT	7	25.5	9.8	23	1.00±0.05	10.0±0.6	5.4 - 7.4	27.5
SFV20D102KT	7	25.5	10.3	23	1.00±0.05	10.0±0.6	5.9 - 7.9	27.5
SFV20D112KT	7	25.5	10.9	23	1.00±0.05	10.0±0.6	6.5 - 8.5	27.5
SFV20D122KT	7	25.5	11.5	23	1.00±0.05	10.0±0.6	7.1 - 9.1	27.5

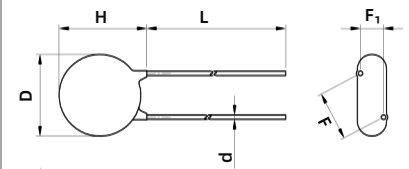

Straight Lead

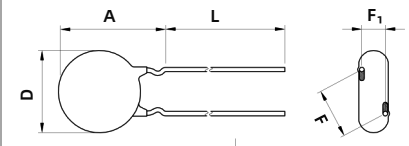

Inward Crimp

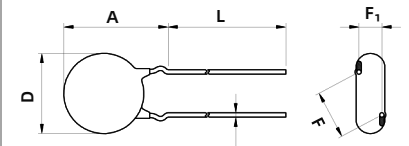

Outward Crimp

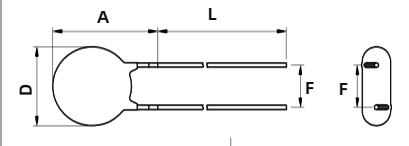

Inline Crimp

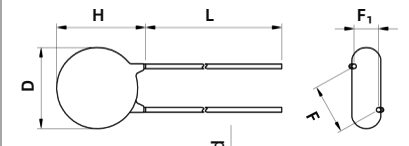

Little Straight Lead

Note:

The above data is for reference only.

MOV

MOV

**Specification**

Model	Surge Level	Max. Continuous Operating Voltage		Varistor Voltage @1 mA DC		Clamping Voltage (Max.)		Max. Peak Current (1 time, 8/20 $\mu$ s)	Max. Energy (10/1000 $\mu$ s)	Typical Capacitance (For reference only) @1 kHz	Agency Approvals					
		Vac	Vdc	Min.	Max.	V <sub>C</sub>	I <sub>P</sub>				S	(pF)	UL	cUL	TUV	CQC
		(V)	(V)	(V)	(V)	(V)	(A)						(kA)	(J)		
SFV20D220KT	S	14	18	20	24	43	20	2	14	18500	○	○	●	●		
SFV20D270KT	S	17	22	24	31	53	20	2	16	13000	○	○	●	●		
SFV20D330KT	S	20	26	30	36	65	20	2	23	11500	○	○	●	●		
SFV20D390KT	S	25	31	35	43	77	20	2	26	8500	○	○	●	●		
SFV20D470KT	S	30	38	42	52	93	20	2	30	8000	○	○	●	●		
SFV20D560KT	S	35	45	50	62	110	20	2	41	7000	○	○	●	●		
SFV20D680KT	S	40	56	61	75	135	20	2	46	6200	○	○	●	●		
SFV20D820KT	S	50	65	74	90	135	100	6.5	38	4900	●	●	●	●		
SFV20D101KT	S	60	85	90	110	165	100	6.5	45	4000	●	●	●	●		
SFV20D121KT	S	75	100	108	132	200	100	6.5	55	3400	●	●	●	●		
SFV20D151KT	S	95	125	135	165	250	100	6.5	70	2700	●	●	●	●		
SFV20D181KT	S	115	150	162	198	300	100	6.5	85	2200	●	●	●	●		
SFV20D201KT	S	130	170	180	220	340	100	6.5	95	2000	●	●	●	●		
SFV20D221KT	S	140	180	198	242	360	100	6.5	100	1800	●	●	●	●		
SFV20D241KT	S	150	200	216	264	395	100	6.5	108	1650	●	●	●	●		
SFV20D271KT	S	175	225	243	297	455	100	6.5	127	1500	●	●	●	●		
SFV20D301KT	S	190	250	270	330	500	100	6.5	136	1300	●	●	●	●		
SFV20D331KT	S	210	275	297	363	550	100	6.5	150	1200	●	●	●	●		
SFV20D361KT	S	230	300	324	396	595	100	6.5	163	1100	●	●	●	●		
SFV20D391KT	S	250	320	351	429	650	100	6.5	180	1000	●	●	●	●		
SFV20D431KT	S	275	350	387	473	710	100	6.5	190	930	●	●	●	●		
SFV20D471KT	S	300	385	423	517	775	100	6.5	220	850	●	●	●	●		
SFV20D511KT	S	320	415	459	561	845	100	6.5	220	780	●	●	●	●		
SFV20D561KT	S	350	460	504	616	925	100	6.5	220	710	●	●	●	●		
SFV20D621KT	S	385	505	558	682	1025	100	6.5	220	650	●	●	●	●		
SFV20D681KT	S	420	560	612	748	1120	100	6.5	230	600	●	●	●	●		
SFV20D751KT	S	460	615	675	825	1240	100	6.5	255	530	●	●	●	●		
SFV20D821KT	S	510	670	738	902	1355	100	6.5	282	500	●	●	●	●		
SFV20D911KT	S	550	745	819	1001	1500	100	6.5	310	440	●	●	●	●		
SFV20D102KT	S	625	825	900	1100	1650	100	6.5	342	400	●	●	●	●		
SFV20D112KT	S	680	895	990	1210	1815	100	6.5	383	360	●	●	●	●		
SFV20D122KT	S	750	990	1080	1320	1980	100	6.5	408	320	●	●	●	●		

● : Approved      ○ : Unauthorized

MOV

MOV

**Specification**

Model	Surge Level	Max. Continuous Operating Voltage		Varistor Voltage @1 mA DC		Clamping Voltage (Max.)		Max. Peak Current (1 time, 8/20 μs)	Max. Energy (10/1000 μs)	Typical Capacitance (For reference only) @1 kHz	Agency Approvals			
		Vac	Vdc	Min.	Max.	V <sub>C</sub>	I <sub>P</sub>				K		(pF)	UL
		(V)	(V)	(V)	(V)	(V)	(A)	(kA)	(J)	UL	cUL	TUV		CQC
SFV20D220KT	K	14	18	20	24	43	20	3	16	18500	○	○	●	●
SFV20D270KT	K	17	22	24	31	53	20	3	19	13000	○	○	●	●
SFV20D330KT	K	20	26	30	36	65	20	3	24	11500	○	○	●	●
SFV20D390KT	K	25	31	35	43	77	20	3	28	8500	○	○	●	●
SFV20D470KT	K	30	38	42	52	93	20	3	34	8000	○	○	●	●
SFV20D560KT	K	35	45	50	62	110	20	3	41	7000	○	○	●	●
SFV20D680KT	K	40	56	61	75	135	20	3	49	6200	○	○	●	●
SFV20D820KT	K	50	65	74	90	135	100	10	56	4900	●	●	●	●
SFV20D101KT	K	60	85	90	110	165	100	10	70	4000	●	●	●	●
SFV20D121KT	K	75	100	108	132	200	100	10	85	3400	●	●	●	●
SFV20D151KT	K	95	125	135	165	250	100	10	106	2700	●	●	●	●
SFV20D181KT	K	115	150	162	198	300	100	10	130	2200	●	●	●	●
SFV20D201KT	K	130	170	180	220	340	100	10	140	2000	●	●	●	●
SFV20D221KT	K	140	180	198	242	360	100	10	155	1800	●	●	●	●
SFV20D241KT	K	150	200	216	264	395	100	10	168	1650	●	●	●	●
SFV20D271KT	K	175	225	243	297	455	100	10	190	1500	●	●	●	●
SFV20D301KT	K	190	250	270	330	500	100	10	210	1300	●	●	●	●
SFV20D331KT	K	210	275	297	363	550	100	10	228	1200	●	●	●	●
SFV20D361KT	K	230	300	324	396	595	100	10	255	1100	●	●	●	●
SFV20D391KT	K	250	320	351	429	650	100	10	275	1000	●	●	●	●
SFV20D431KT	K	275	350	387	473	710	100	10	305	930	●	●	●	●
SFV20D471KT	K	300	385	423	517	775	100	10	350	850	●	●	●	●
SFV20D511KT	K	320	415	459	561	845	100	10	360	780	●	●	●	●
SFV20D561KT	K	350	460	504	616	925	100	10	380	710	●	●	●	●
SFV20D621KT	K	385	505	558	682	1025	100	10	390	650	●	●	●	●
SFV20D681KT	K	420	560	612	748	1120	100	10	400	600	●	●	●	●
SFV20D751KT	K	460	615	675	825	1240	100	10	420	530	●	●	●	●
SFV20D821KT	K	510	670	738	902	1355	100	10	460	500	●	●	●	●
SFV20D911KT	K	550	745	819	1001	1500	100	10	510	440	●	●	●	●
SFV20D102KT	K	625	825	900	1100	1650	100	10	565	400	●	●	●	●
SFV20D112KT	K	680	895	990	1210	1815	100	10	620	360	●	●	●	●
SFV20D122KT	K	750	990	1080	1320	1980	100	10	660	320	●	●	●	●

● : Approved      ○ : Unauthorized

MOV

MOV

**Specification**

Model	Surge Level	Max. Continuous Operating Voltage		Varistor Voltage @1 mA DC		Clamping Voltage (Max.)		Max. Peak Current (1 time, 8/20 μs)	Max. Energy (8/20 μs)	Typical Capacitance (For reference only) @1 kHz	Agency Approvals			
		Vac	Vdc	Min.	Max.	V <sub>C</sub>	I <sub>P</sub>	H		(pF)	UL	cUL	TUV	CQC
		(V)	(V)	(V)	(V)	(V)	(A)	(kA)	(J)		UL	cUL	TUV	CQC
SFV20D201KT	H	130	170	180	220	340	100	13	300	2000	●	●	●	●
SFV20D221KT	H	140	180	198	242	360	100	13	320	1800	●	●	●	●
SFV20D241KT	H	150	200	216	264	395	100	13	340	1650	●	●	●	●
SFV20D271KT	H	175	225	243	297	455	100	13	380	1500	●	●	●	●
SFV20D301KT	H	190	250	270	330	500	100	13	400	1300	●	●	●	●
SFV20D331KT	H	210	275	297	363	550	100	13	440	1200	●	●	●	●
SFV20D361KT	H	230	300	324	396	595	100	13	470	1100	●	●	●	●
SFV20D391KT	H	250	320	351	429	650	100	13	510	1000	●	●	●	●
SFV20D431KT	H	275	350	387	473	710	100	13	550	930	●	●	●	●
SFV20D471KT	H	300	385	423	517	775	100	13	600	850	●	●	●	●
SFV20D511KT	H	320	415	459	561	845	100	13	650	780	●	●	●	●
SFV20D561KT	H	350	460	504	616	925	100	13	700	710	●	●	●	●
SFV20D621KT	H	385	505	558	682	1025	100	13	700	650	●	●	●	●
SFV20D681KT	H	420	560	612	748	1120	100	13	800	600	●	●	●	●
Model	Surge Level	Max. Continuous Operating Voltage		Varistor Voltage @1 mA DC		Clamping Voltage (Max.)		Pulse Impact Performance (40 times) (1.2/50 μs & 8/20 μs)	Max. Energy (10/1000 μs)	Typical Capacitance (For reference only) @1 kHz	Agency Approvals			
		Vac	Vdc	Min.	Max.	V <sub>C</sub>	I <sub>P</sub>	Q		(pF)	UL	cUL	TUV	CQC
		(V)	(V)	(V)	(V)	(V)	(A)	(kV)	(J)		UL	cUL	TUV	CQC
SFV20D201KT	Q	130	170	180	220	340	100	10	140	2000	●	●	●	●
SFV20D221KT	Q	140	180	198	242	360	100	10	155	1800	●	●	●	●
SFV20D241KT	Q	150	200	216	264	395	100	10	168	1650	●	●	●	●
SFV20D271KT	Q	175	225	243	297	455	100	10	190	1500	●	●	●	●
SFV20D301KT	Q	190	250	270	330	500	100	10	210	1300	●	●	●	●
SFV20D331KT	Q	210	275	297	363	550	100	10	228	1200	●	●	●	●
SFV20D361KT	Q	230	300	324	396	595	100	10	255	1100	●	●	●	●
SFV20D391KT	Q	250	320	351	429	650	100	10	275	1000	●	●	●	●
SFV20D431KT	Q	275	350	387	473	710	100	10	305	930	●	●	●	●
SFV20D471KT	Q	300	385	423	517	775	100	10	350	850	●	●	●	●
SFV20D511KT	Q	320	415	459	561	845	100	10	360	780	●	●	●	●
SFV20D561KT	Q	350	460	504	616	925	100	10	380	710	●	●	●	●
SFV20D621KT	Q	385	505	558	682	1025	100	10	390	650	●	●	●	●
SFV20D681KT	Q	420	560	612	748	1120	100	10	400	600	●	●	●	●

MOV

MOV



**Performance Curve (For reference only )**

- Max. Peak Current Derating Curves

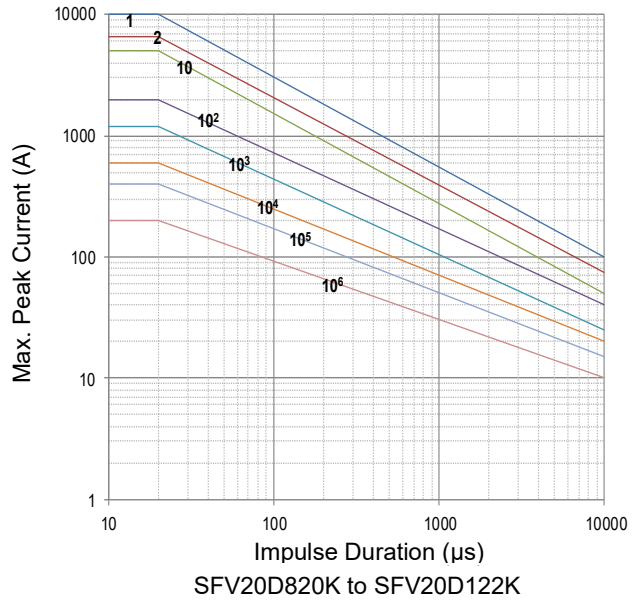
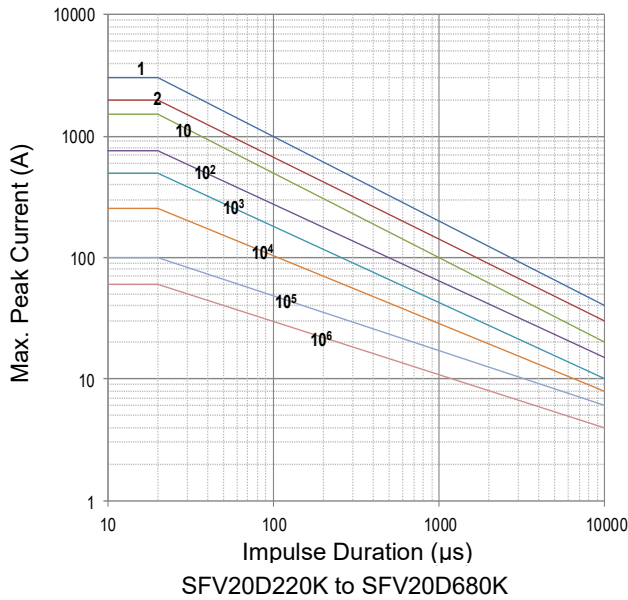

Note: 1, 2, 10, 10<sup>2</sup>, 10<sup>3</sup>, 10<sup>4</sup>, 10<sup>5</sup>, 10<sup>6</sup> Stand for Repetitions.

- Voltage-Current Characteristic Curves

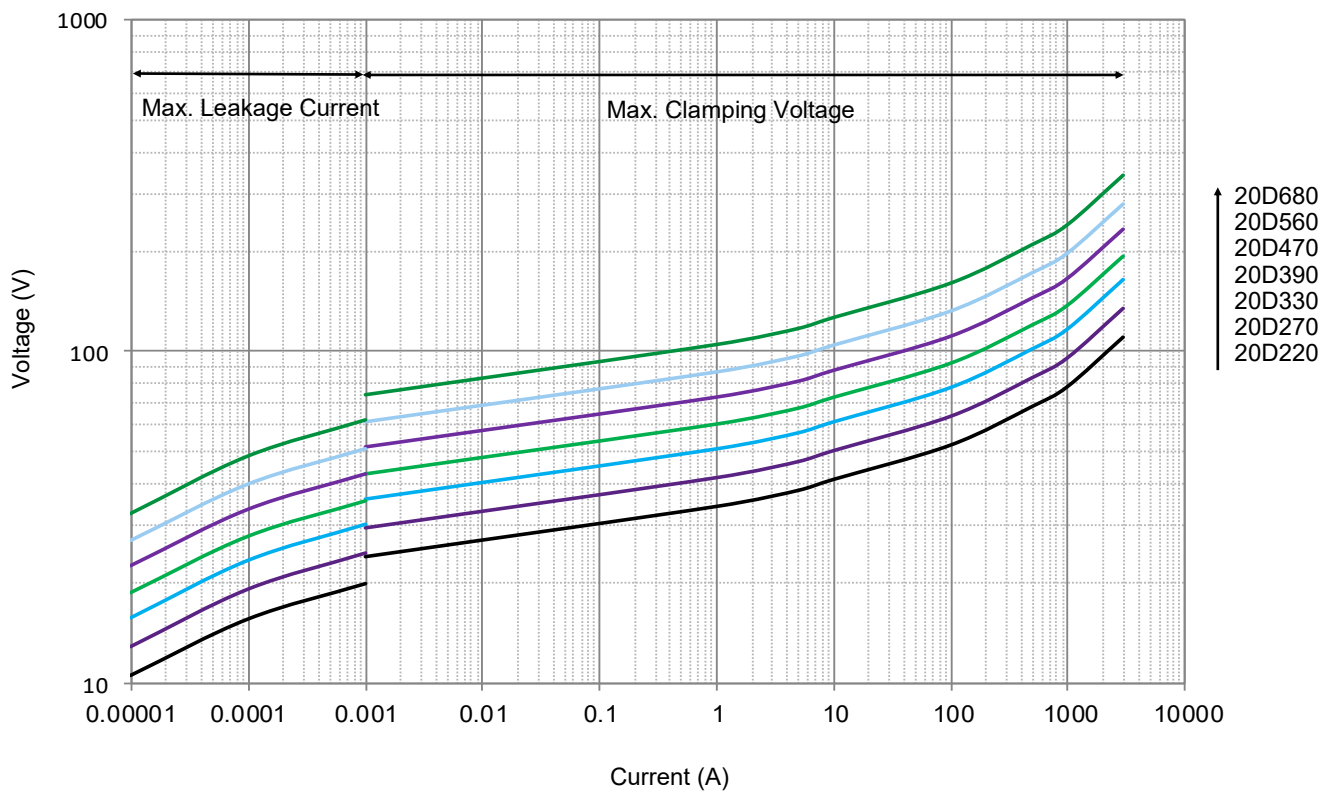

• Voltage-Current Characteristic Curves

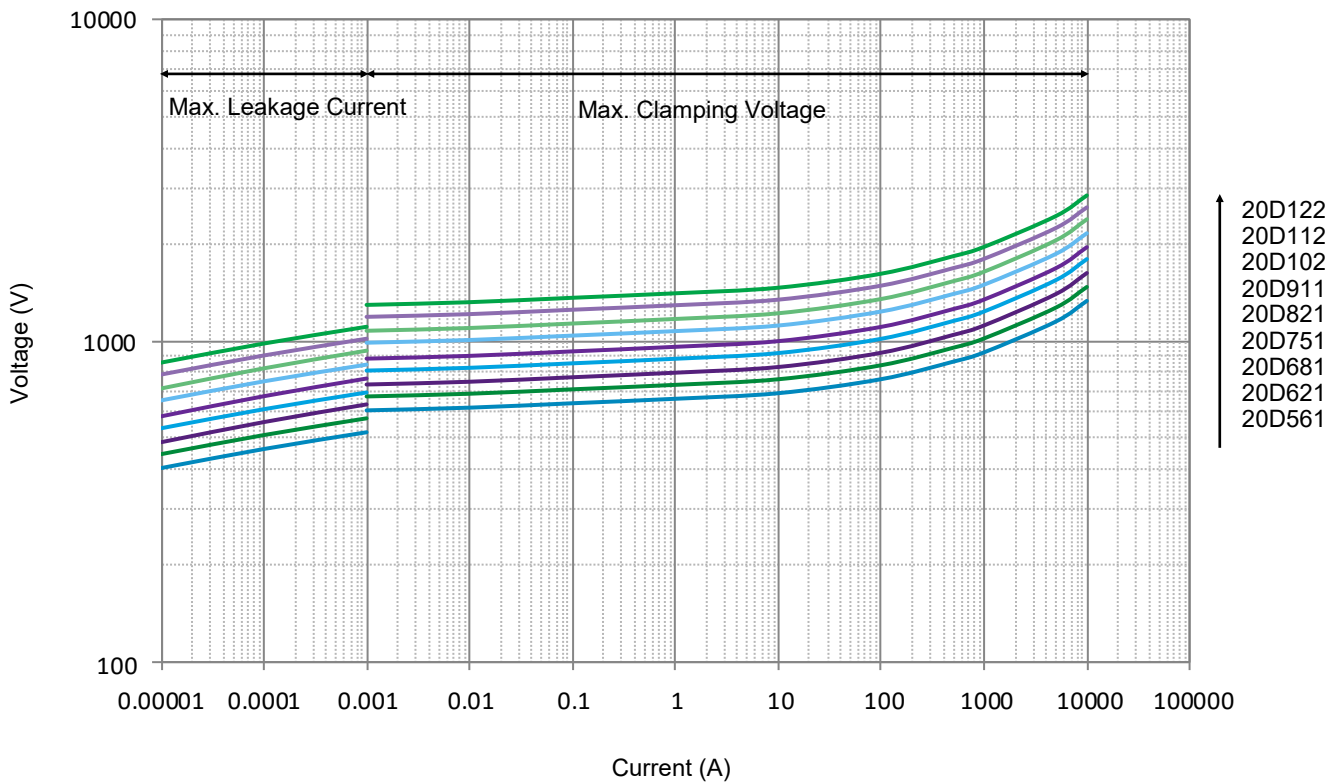
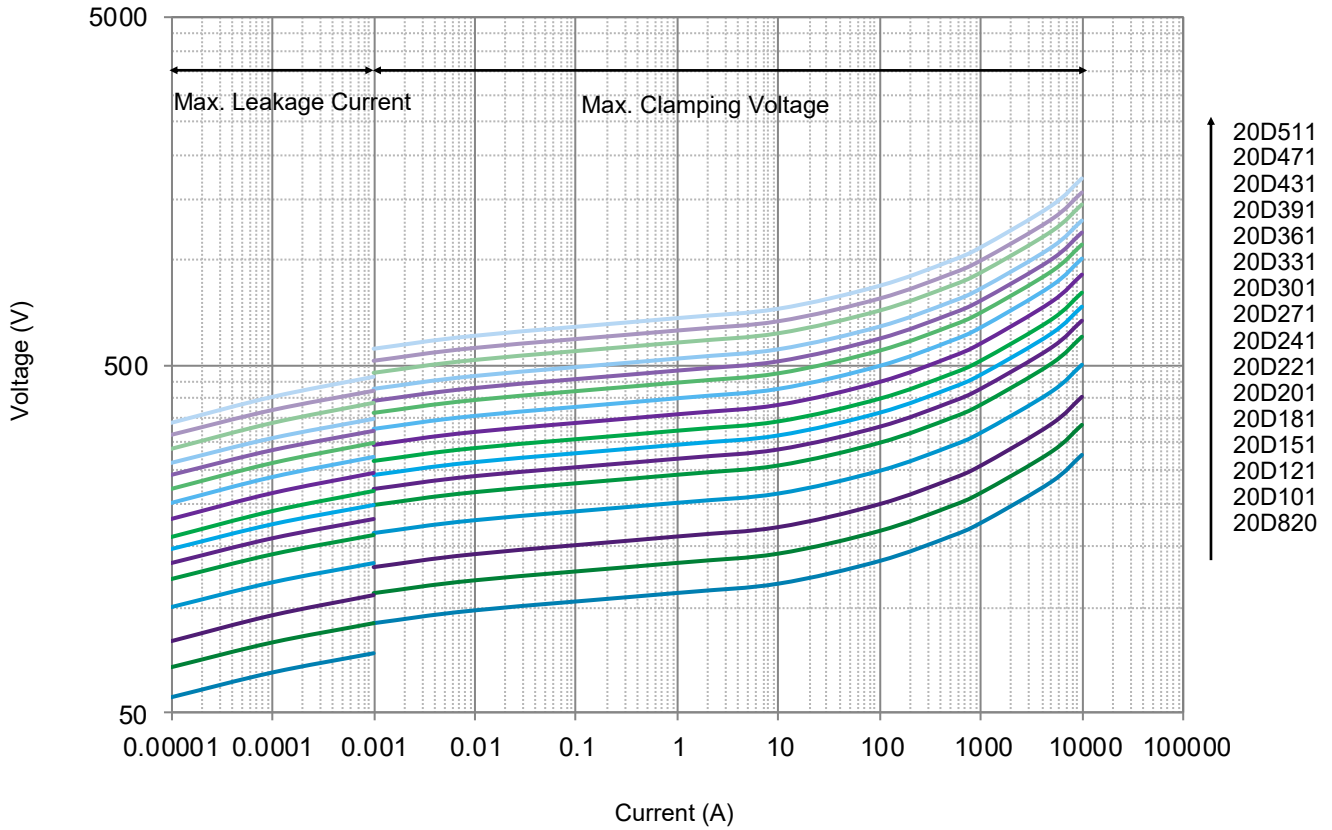

MOV

MOV

## Soldering Parameters

### Wave Soldering Parameters

The wave soldering parameters are for reference only. When MOV is for practice use, some related validation is recommended.

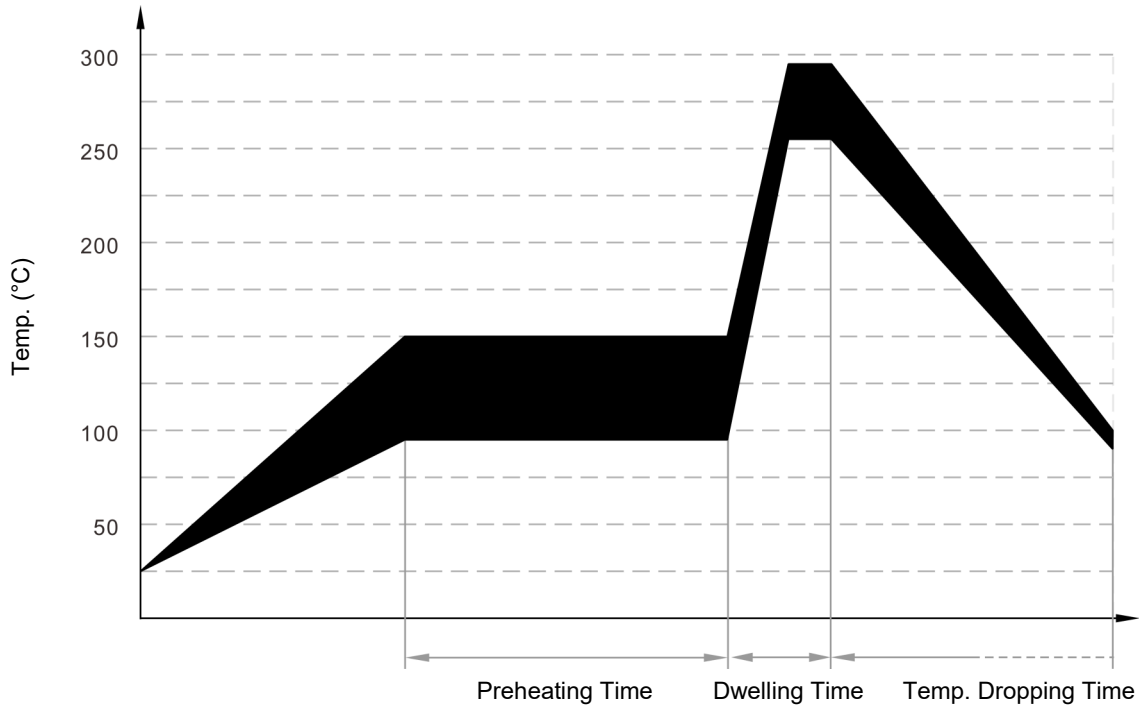

Wave Soldering Curve

Item	Temp. (°C)	Time (s)
Preheating	90 to 150	<150
Dwelling	255 to 290	3 to 10

### Recommended Hand-Soldering Parameters

Item	Condition
Temp. of Solder Head	350 °C (max.)
Soldering Time	4 seconds (max.)

### Packaging Information

- Bulk Packaging (Code: BUL)
- Bulk Packaging Quantity & Weight.

Series	Nominal Varistor Voltage	PE Bag	Box	Carton	G. W / Carton (365 × 265× 245)
	(V)	(PCS)	(PCS)	(PCS)	(kg)±10%
20D	220 - 471	100	200	1200	4 - 8
	511 - 821	80	160	960	6 - 13
	911 - 122				

Note:  
Other lead length packaging information, please contact SETsafe | SETfuse.

All Dimensions in mm

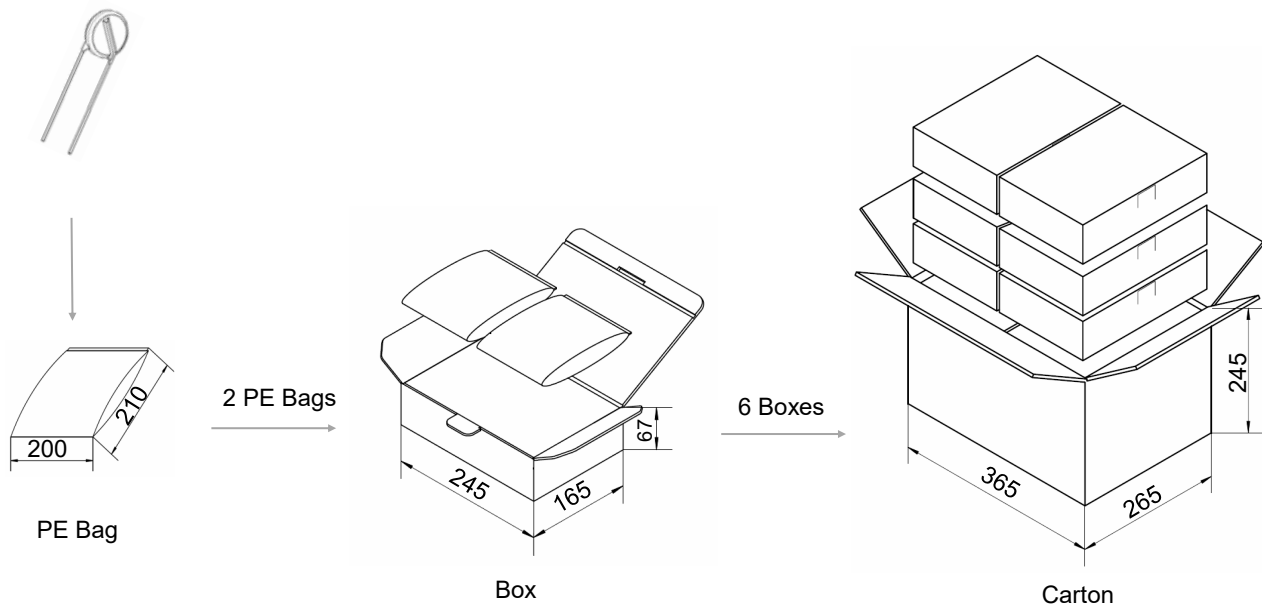

MOV

MOV

**Packaging Information**

- Tape Packaging (Code: 1EB)

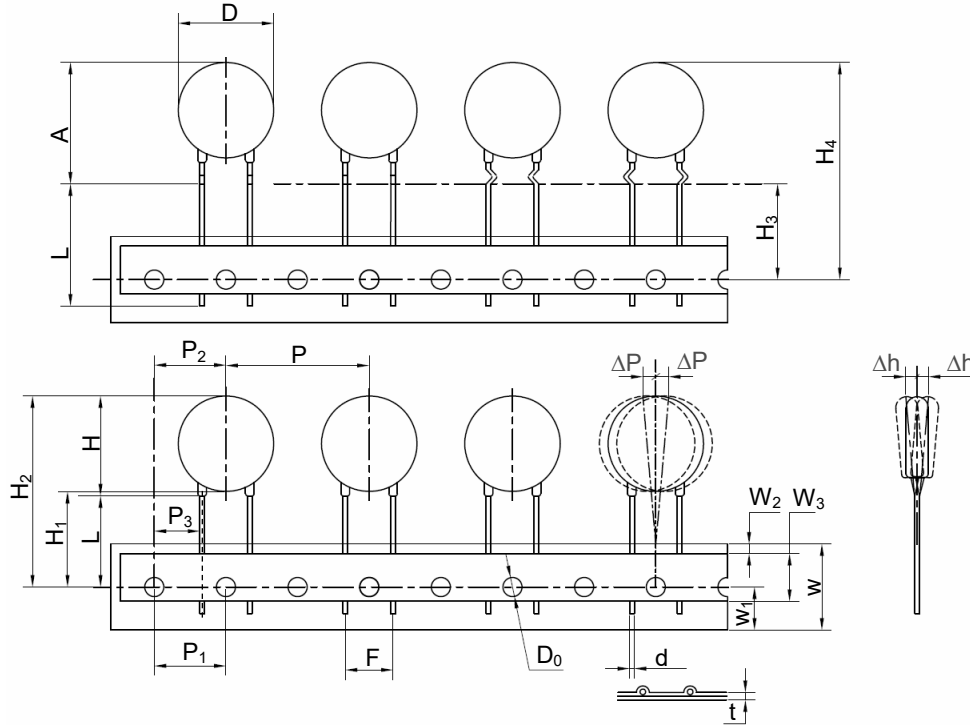

Dimensions (mm)	
Symbol	Dimensions
P	30.0±1.0
P <sub>1</sub>	15.0±0.3
P <sub>2</sub>	15.0±1.3
P <sub>3</sub>	10.0±1.0
ΔP(max.)	1.0
W	18.0±1.0
W <sub>1</sub>	9.0±1.0
W <sub>2</sub> (max.)	3.0
W <sub>3</sub>	10.0±2.0
H(max.)	25.5
H <sub>1</sub>	18.0 <sup>+2.0</sup> <sub>-0</sub>
H <sub>2</sub> (max.)	45.0
H <sub>3</sub>	18.0 <sup>+2.0</sup> <sub>-0</sub>
H <sub>4</sub> (max.)	48.0
Δh(max.)	2.0
t(max.)	0.6
D(max.)	23.0
D <sub>0</sub>	4.0±0.2
d	1.00±0.05
A(max.)	27.5
F	10.0±0.5
L(min.)	Taping

- Tape Packaging Quantity & Weight.

Series	Nominal Varistor Voltage (V)	Box (PCS)	Carton (PCS)	G. W / Carton (365 × 265 × 415) (kg)±10%
20D	102 - 122	200	1200	14 - 16
	751 - 911	250	1500	14 - 16
	561 - 681	300	1800	13 - 15
	431 - 511	350	2100	13 - 14
	331 - 391	400	2400	12 - 14
	560 - 680			12 - 13
	241 - 301	450	2700	11 - 13
	390 - 470			11 - 12
	181 - 221	500	3000	10 - 12
	820 - 121			10 - 11
	220 - 330			9 - 11

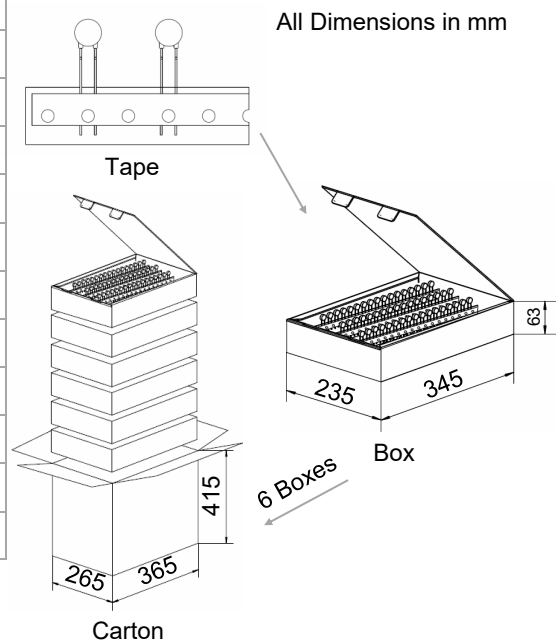

**Packaging Information**

- Tape Packaging (Code: 1AB)

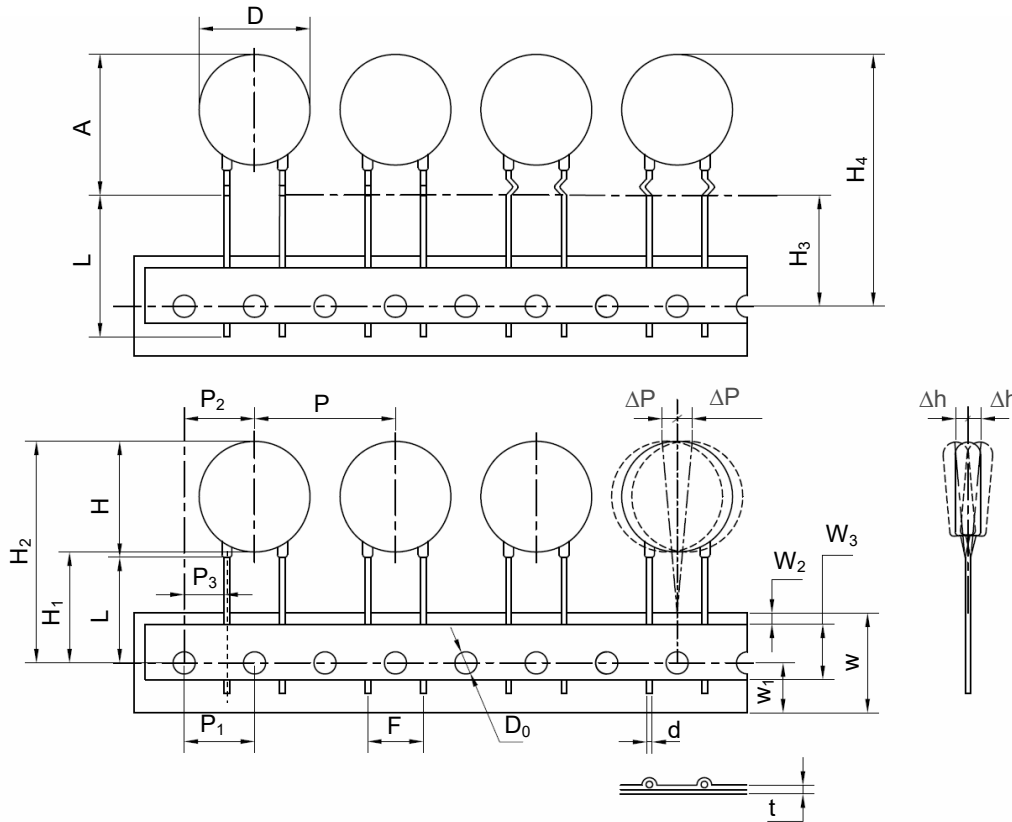

**Dimensions (mm)**

Symbol	Dimensions
P	25.4±1.0
P <sub>1</sub>	12.7±0.3
P <sub>2</sub>	12.7±1.3
P <sub>3</sub>	7.7±0.7
ΔP(max.)	1.0
W	18.0±1.0
W <sub>1</sub>	9.0±1.0
W <sub>2</sub> (max.)	3.0
W <sub>3</sub>	10.0±2.0
H(max.)	25.5
H <sub>1</sub>	18.0 <sup>+2.0</sup> <sub>-0</sub>
H <sub>2</sub> (max.)	45.0
H <sub>3</sub>	18.0 <sup>+2.0</sup> <sub>-0</sub>
H <sub>4</sub> (max.)	48.0
Δh(max.)	2.0
t(max.)	0.6
D(max.)	23.0
D <sub>0</sub>	4.0±0.2
d	1.00±0.05
A(max.)	27.5
F	10.0±1.0
L(min.)	Taping

- Tape Packaging Quantity & Weight.

Series	Nominal Varistor Voltage	Box	Carton	G. W / Carton (365 × 265 × 415)
	(V)	(PCS)	(PCS)	(kg)±10%
20D	102 - 122	250	1500	19 - 22
	751 - 911	300	1800	18 - 20
	621 - 681	350	2100	18 - 19
	471 - 561	400	2400	17 - 19
	391 - 431	450	2700	17 - 18
	680			17
	301 - 361	500	3000	17 - 18
	560			17
	221 - 271	550	3300	17
	151			16
	390 - 470	600	3600	15 - 17
	181 - 201			14 - 15
	820 - 121			13 - 15
	220 - 330			12 - 14

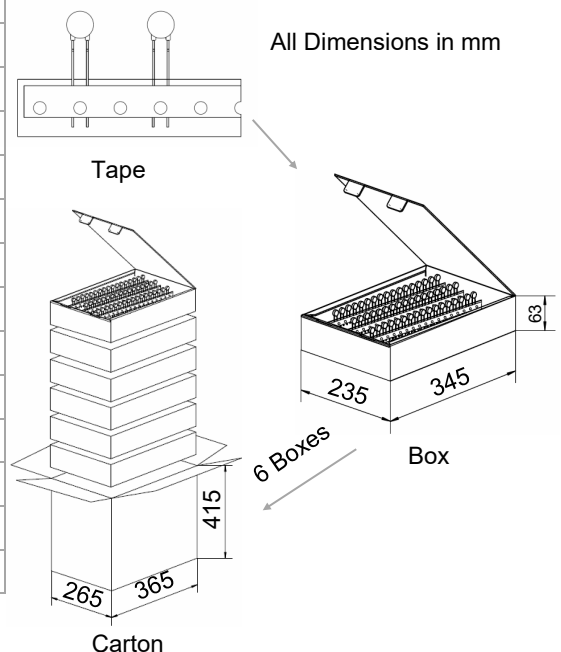



# ATTENTION

MOV

MOV

## Usage

1. Varistor must operated in the specified ambient temp.
2. Do not clean the varistor with strong polar solvent such as ketone, esters, benzene and halogenated hydrocarbon.
3. Please do not apply severe vibration, shock or pressure to MOV.
4. Please fix lead wires when bending or cutting. The distance between the bending point and the sealing of MOV shall be greater than 2 mm.

## Replacement

If varistor is visually damaged, please replace it.

## Storage

1. Storage Temp. Range: (-40 to +125) °C
2. Relative Humidity :  $\leq 75\%$  RH
3. Altitude: <2000 m
4. Do not store the MOV at the high temp., high humidity or corrosive gas environment, to avoid influencing the solder-ability of the lead wires, the product shall be used up within 1 year after receiving the goods.

## Environmental Conditions

1. Varistor should neither be exposed to the open air, nor direct sunshine.
2. Varistor should avoid rain, water vapor or other condition of high temp. and high humidity.
3. Varistor should avoid sand dust, salt spray, or other harmful gases.

# MOV

Metal Oxide Varistor

SFV20D T Series

## Max. Typical Capacitance of Varistor

The typical capacitance of varistor is listed in the specifications. Designers may refer to it when designing MOV in high frequency circuit.

## Installation

### Mechanical Stress

Do not knock MOV when installing, to avoid mechanical damage.